

# XFP-CX4

## 10GBASE-CX4 Copper XFP Transceiver

### Overview

The XFP-CX4 copper transceiver provides cost-effective and reliable bandwidth transport of up to 12.5 Gigabits over distances of up to 15 meters. The product provides 4 full-duplex, 3.125 Gigabaud transmit and receive channels over a single parallel copper cable that is transparent to the user. It not only offers the ability to scale net bandwidth in 10 Gigabit increments, it also mates directly with the industry standard MDI electrical socket.

The XFP-CX4 is ideal for telecom central office and enterprise data center applications. Whether extending bandwidth in-system or inter-connecting between systems, the XFP-CX4 transceiver offers an attractive combination of high performance and low cost in an industry standard form factor.

### Features

- 10GBASE-CX4 compliant (IEEE 802.3ak)
- 15 meters reach on appropriate CX4-grade copper cable - 4-channel full-duplex copper cable support
- MSA compatible form factor (XFP)
- XFI high-speed host electrical interface
- Serial two-wire interface with SCL/SDA lines
- Z-axis front panel pluggable

### Product Overview



XFP-CX4

- 30-pin host connector
- MDI socket for CX4, Infiniband, and Fiber Channel compatibility
- XFP power level 2 compliance
- Hot-pluggable electronics
- 0°C to 70°C case temperature operating range
- RoHS 5/6 Compliance

### Applications

- 10 Gigabit Ethernet
- Enterprise routers
- Workgroup routers and switches
- Servers
- NIC cards
- Storage interfaces
- Supercomputers

### Absolute Maximum Ratings

Parameter	Symbol	Min.	Typical	Max.	Units	Notes
Storage Temperature	T <sub>s</sub>	-20	-	100	°C	1
Supply Voltage (3.3 V)	V <sub>cc3</sub>	-0.5	-	3.6	V	1
Supply Voltage (1.8 V)	V <sub>cc2</sub>	-0.5	-	2.0	V	1
CMOS Data Input Voltage	V <sub>i</sub>	-0.3	-	V <sub>CCA</sub> + 0.3	V	1
CML Output Current	I <sub>b</sub>	-50	-	50	mA	1
Relative Humidity	RH	5	-	95	%	1,2

#### Notes:

1. Exceeding the absolute maximum ratings can permanently damage the module.
2. Non-condensing. Not intended for applications requiring aqueous wash.

### Recommended Operating Conditions

Parameter	Symbol	Min.	Typical	Max.	Units	Notes
Operating Case Temperature	T <sub>c</sub>	+0	-	+70	°C	-
Supply Voltage (3.3 V)	V <sub>cc3</sub>	3.14	3.3	3.47	V	±5%
Power Supply Rejection	P <sub>SR</sub>	-	-	200	MV <sub>P-P</sub>	1
Supply Voltage (1.8 V)	V <sub>cc2</sub>	1.71	1.80	1.89	V	±5%
Signaling Rate	-	-	10.3125	-	GBd	2
Clock Skew (from 10.3125 Gbps)	-	-	-	100	ppm	-
SCL Clock Rate	SCL	-	-	400	kHz	-
SCL/SDA I/O Voltage (LVTTTL) (host pull to 3.3 V)	V <sub>L</sub> / V <sub>H</sub>	-0.3 / V <sub>cc3</sub> *0.7	-	V <sub>cc3</sub> *0.3 / V <sub>cc3</sub> +0.5	V	-
Serial Data Input Termination Differential	RDL	-	100	-	Ohm	3

#### Notes:

1. Tested with 200 mVp-p broadband noises in the frequency range from 44 kHz to 400 MHz on the 3.3V Vcc supply.
2. Limited to 10 gb/s Ethernet LAN data.
3. The high-speed serial transmitter's data inputs are internally terminated for use with external transmission lines that have a characteristic impedance of Z<sub>o</sub> = 100 Ohms differential.

### Receiver Specifications (Electrical)

Parameter	Symbol	Min.	Typical	Max.	Units	Notes
Cable Type	-	-	Standard 4 channel CX4 cable			-
Connector Durability	100	-	-	-	-	1
Connector Style	-	-	Industry standard MDI copper connector			-

#### Notes:

1. Insertions/extractions

## Electrical Characteristics, General

Parameter	Symbol	Min.	Typical	Max.	Units	Notes
Supply Voltage (3.3 V)	Vcc3	3.14	3.3	3.47	V	-
Supply Current (3.3 V)	Icc3	-	100	-	mA	-
Supply Voltage (1.8 V)	Vcc2	1.71	1.80	1.89	V	-
Supply Current (1.8 V)	Icc2	-	500	-	mA	-
Power Dissipation	P <sub>DIST</sub>	-	-	2.0	W	-
TX_Dis, P_Down/RST Voltage	V <sub>L</sub> / V <sub>H</sub>	-0.3 / 2.0	-	0.8 / Vcc3+0.3	V	-
RX_Los, Mod_NR, Interrupt	V <sub>L</sub> / V <sub>H</sub>	0 / Host_Vcc-0.5	-	0.40 / Host_Vcc+0.31	V	-
P_Down Reset Time	-	10	-	-	μs	-

## Electrical Transmitter Characteristics (Cable Side, CX4 Side)

Parameter	Symbol	Min.	Typical	Max.	Units	Notes
Differential Peak-to-Peak Output Voltage Swing	V <sub>out</sub>	800	-	1200	mV	1
Differential Voltage Difference (lane to lane)	V <sub>out</sub>	-	-	175	mV	-
Common Mode Output Voltage	V <sub>com</sub>	0.5	0.75	1.0	V	-
Data Output Rise Time (20%/80%)	t <sub>r</sub>	60	-	130	ps	2
Data Output Fall Time (80%/20%)	t <sub>f</sub>	60	-	130	ps	2
Deterministic Jitter	DJ	-	-	0.17	UI	-
Total Jitter	TJ	-	-	0.35	UI	-
Vcc for Active Module (when active module present)	Vcc	3.15	3.3	3.46	V	-
Resistor attached to type_sense for turning on power to active module	R <sub>type_sense</sub>	-	5.1	-	KOhm	-

Notes:

- V<sub>out</sub> = [(V<sub>out</sub>+p-p) - (V<sub>out</sub>-p-p)]
- Power will not be supplied to that pin if a copper cable or any module without a resistor of proper value attached to the type\_sense pin. The resistor should be 5.1K ± 10%

## Electrical Receiver Characteristics (Cable Side, CX4 Side)

Parameter	Symbol	Min.	Typical	Max.	Units	Notes
Receiver Differential Input Voltage	V <sub>in</sub>	100	-	2000	MV <sub>P-P</sub>	1
Deterministic Jitter Tolerance	DJ	0.65	-	-	UI	2
Total Jitter Tolerance	TJ	0.75	-	-	UI	-

Notes:

- V<sub>in</sub> = [(V<sub>in</sub>+p-p) - (V<sub>in</sub>-p-p)]
- If the incoming DJ is caused by copper cable then it can be compensated by equalization in the receiver. In this case the DJ tolerance could be as high as 1UI.

## Electrical Pin Map (Cable Side, CX4 Side)

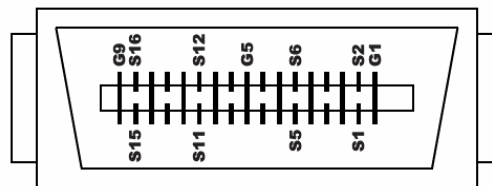

Front-View CX4 Connector

## Electrical Transmitter Characteristics (Cable Side, CX4 Side)

Parameter	Symbol
G1	GND
G2	ODIS
G3	GND
G4	GND
G5	GND
G6	Fault-
G7	Type_Sense
G8	Vcc
G9	GND
S1	RX0+
S2	RX0-
S3	RX1+
S4	RX1-
S5	RX2+
S6	RX2-
S7	RX3+
S8	RX3-
S9	TX3-
S10	TX3+
S11	TX2-
S12	TX2+
S13	TX1-
S14	TX1+
S15	TX0-
S16	TX0+
Housing	Chassis Ground

### Note:

The cable side pin assignment is compatible with the Fiber Channel standard proposal (PI-2) that supports active modules. When a copper cable is plugged in, then all G\_signals are ground.

## Signal Description, Cable Side, CX4 Side

Signal	Functional Description
GND	Circuit ground. Connect these pins to the host system's circuit common ground plane.
Vcc	Power supply provides +3.3 VDC when an active module (QTR3400) is plugged into the socket. Output is AC ground when a regular copper cable is present.
TX0+ through TX3+	CML compatible transmitter data out+ for channels 0 through 3, respectively.
TX0- through TX3-	CML compatible transmitter data out- for channels 0 through 3, respectively.
RX0+ through RX3+	CML compatible transmitter data in+ for channels 0 through 3, respectively.
RX0- through RX3-	CML compatible transmitter data in- for channels 0 through 3, respectively.
ODIS	Used to control the active module. Grounded in this CX4 implementation.
Type_Sense	Used to determine whether or not active module is present. It is an AC ground.
Fault-	Transmitter Fault signal or Loss signal from receiver side. Grounded in this CX4 implementation.

## Electrical Pin Map, Host Side, XFI Side

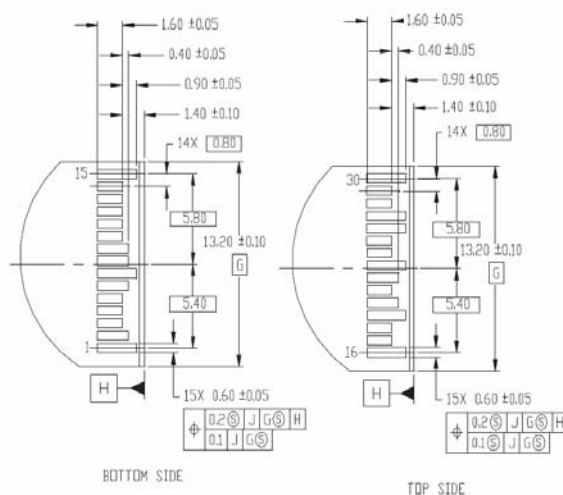



**Electrical Pin Map, Host Side, XFI Side, Bottom Side of Board**

Pin	Logic	Name	Functional Description	Notes
1	-	GND	Module Ground	1
2	VEE5	Optional	-5.2 V power supply	-
3	LVTTTL-I	Mod_DeSel	Module De-select; When held low allows module to respond to 2-wire serial interface	-
4	LVTTTL-O	Interrupt_N	Indicates presence of an important condition which can be read over the 2-wire serial interface	2
5	LVTTTL-I	TX_DIS	Transmitter Disable; Turns off transmitter laser output	-
6	VCC5	+5 V	Power supply	-
7	-	GND	Module Ground	1
8	-	Vcc3	+3.3 V Power Supply	-
9	-	Vcc3	+3.3 V Power Supply	-
10	LVTTTL-I/O	SCL	2-Wire Serial Interface Clock	2
11	LVTTTL-I/O	SDA	2-Wire Serial Interface Data Line	2
12	LVTTTL-O	Mod_Abs	Indicates module is not present. Grounded in the module	2
13	LVTTTL-O	Mod_NR	Module Not Ready; Indicating module operational fault	2
14	LVTTTL-O	RX_LOS	Receiver Loss of Signal Indicator	2
15	-	GND	Module Ground	1
16	-	GND	Module Ground	1
17	CML-O	RD_N	Receiver Inverted Data Output	-
18	CML-O	RD_P	Receiver Non-Inverted Data Output	-
19	-	GND	Module Ground	1
20	-	Vcc2	+1.8 V Power Supply	-
21	LVTTTL-I	P_Down/RST	Power Down; When high, requires the module to limit power consumption to 1.5 W or below. 2-wire serial interface must be functional in the low power mode. Reset; The falling edge initiates a complete reset of the module including the 2-wire serial interface, equivalent to a power cycle.	-
22	-	Vcc2	+1.8 V Power Supply	-
23	-	GND	Module Ground	1
24	PECL-I	RefCLK_N	Reference Clock Non-Inverted Input, AC coupled on the host board	-
25	PECL-I	RefCLK_P	Reference Clock Inverted Input, AC coupled on the host board	-
26	-	GND	Module Ground	1
27	-	GND	Module Ground	1
28	CML-I	TD_N	Transmitter Inverted Data Input	-
29	CML-I	TD_P	Transmitter Non-Inverted Data Input	-
30	-	GND	Module Ground	1

Notes:

1. XFP-CX4 module ground pins are isolated from the module case ground.
2. Must be pulled up with 4.7 K-10 KOHms to a voltage between 3.15 V and 3.45 V on the host board.



Electrical Pin Map, Host Side, XFI Side

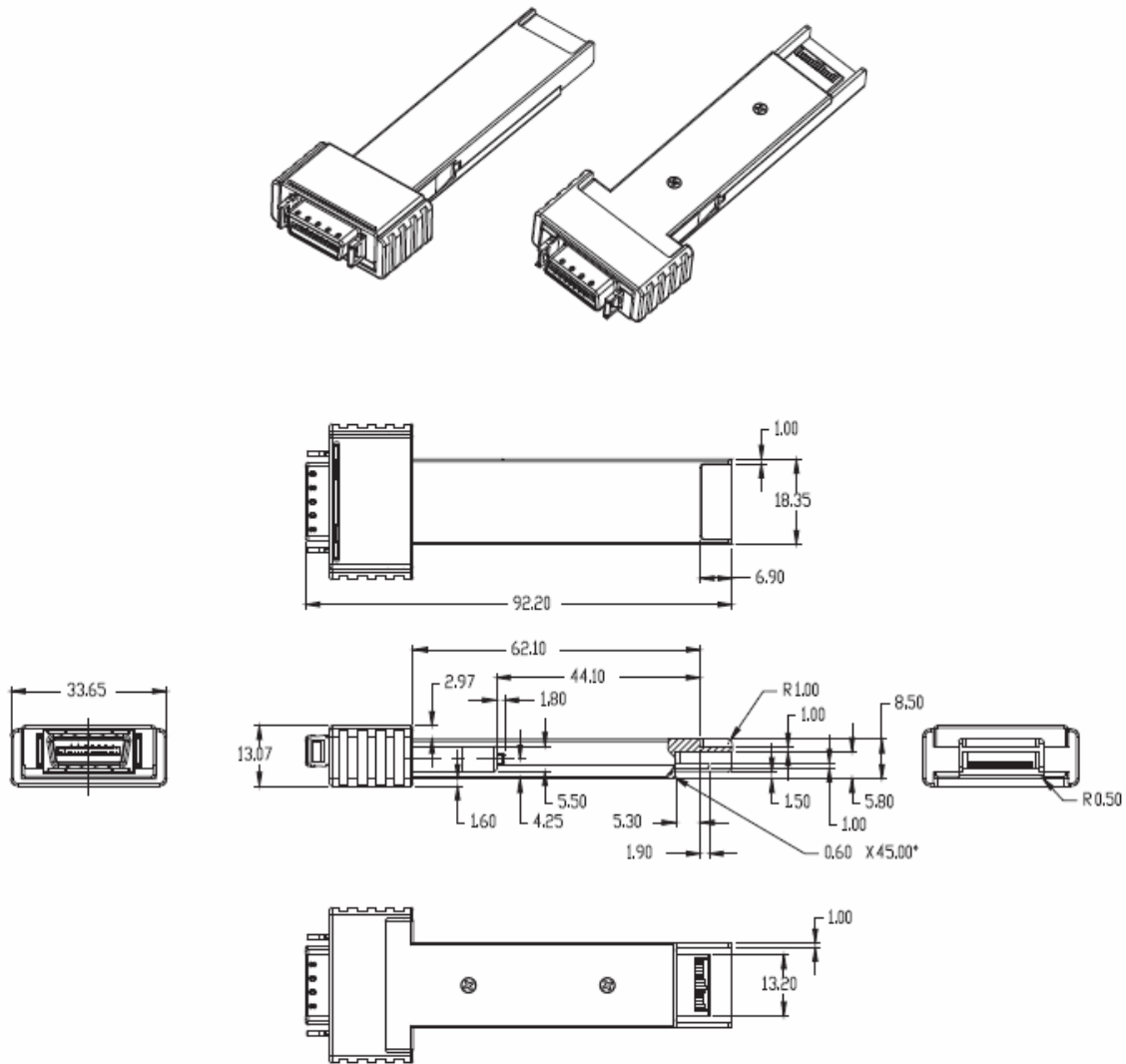

Ordering Information

Model	Description	Data Rate	Distance (m)
XFP-CX4	10 GbE-CX4 Copper XFP Transceiver	Up to 12.5 Gbps	15

\* Distance may vary based on properties of the transponder

Source: Product Datasheet from MRV Manufacturer

About Cell Technology

Cell Technology headquartered at Hong Kong SAR, a network & security technology provider specializes in design, develop and deliver innovative and intelligent IP packet processing platform into software and hardware appliances. Cell product solutions including Cell IPS, UTM, CMC, Janus, TMS, NetsVision and NetsAccess address the business needs that optimize the IP network performance, secure the network security and resiliency, and manage the quality of IP services. For more information, please visit [www.cell-technology.net](http://www.cell-technology.net).